

Pass Through Boot Assembly

Assembly Part # 10-01-210

For new construction wall installations only. Attaches to framing using the Rheia Hanger Bar Assembly (00-00-240), or via support blocking. Includes an adjustable damper blade. Must be used with Rheia-approved Slotted Wall Diffusers (10-04-090 or 10-04-091).

SPECIFICATIONS

Intended Use

For installation into 2x4 or larger wall framing or steel stud framing. Stud spacing: Max. 24" o.c. Min. 16" o.c. (when using Hanger Bar). For optimum performance locate the center of the boot between 4 1/2" and 10" from the upper edge of the wall top plate.

Material

Pass-through Boot: Flame-retardant Polycarbonate /ABS blend.
 Damper Blade: Flame-retardant Polycarbonate /ABS blend.
 100% recyclable.

Installation

Follow Rheia's Installation Guidelines for detailed installation procedures and practices.
 When using the Rheia Hanger Bar, once the boot is correctly positioned, fasten the boot to the Hanger Bar using a sheet metal screw with a minimum length of 3/8".
 When mounting the Pass Through Boot directly to framing, use two pan-head wood screws with a minimum length of 5/8".

Listings

Manufactured with UL94 V-0 rated engineering thermoplastic.

Warranty

2-year limited warranty.
 For warranty information go to www.rheiacomfort.com/contact.

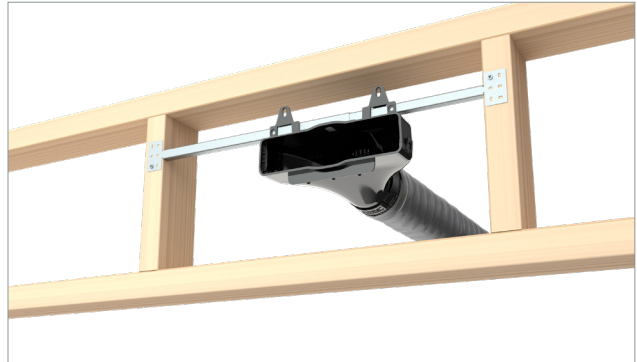

Pass Through Boot Assembly installed with Hanger Bar

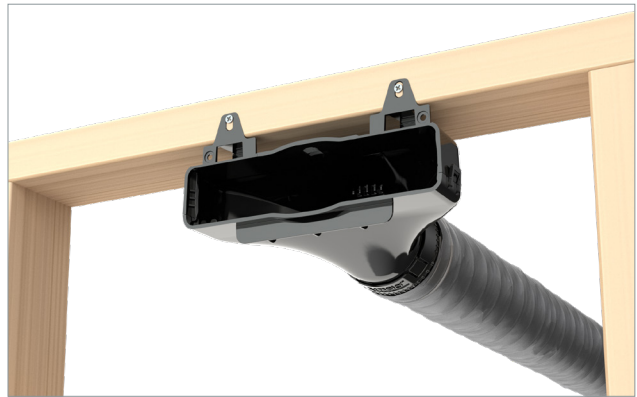

Pass Through Boot Assembly directly to framing



Pass Through Boot Assembly with Damper

DIMENSIONS

Assembly Dimensions (with damper closed)

Length 6.2" (157.5 mm)

Width 9.1" (230 mm)

Height 4.7" (120.5 mm)

Assembly Weight: 0.47 lbs.