

45-Degree Elbow Extension

Part #s: 10-01-020

The 45-Degree Elbow Extension is used when a duct is required to make a tight bend, in which case one or two elbows will prevent compromised air flow in the duct. The elbow is designed to connect with other components. To ensure acceptable airflow, two elbows are used to make a 90 degree duct transition, when the inside radius of the duct transition is less than the diameter of the duct.

SPECIFICATIONS

Elbows are part of the Rheia snap-fit system used to connect and seal all components together, which is sufficiently air tight to not require additional sealing with tape or mastic. A fully assembled system will comply with industry standards for air leakage.

Intended Use

For use with 3" or 4" duct. The 45-Degree Elbow Extension connects duct and components in various corner transitions. Building code requires the use of an elbow fitting when the inside radius of a duct is less than the diameter of the duct.

Material

Flame retardant Polycarbonate / ABS blend.
Color: Black.
100% recyclable.

Installation

Follow Rheia's Installation Guidelines for detailed installation procedures and practices.

Listings

UL 181C: Outline of Investigation for Non-Metal Joining Accessories for Flexible Air Ducts and Air Connectors (MH64419)

UL2043: Standard for Fire Test for Heat and Visible Smoke Release for Discrete Products and Their Accessories Installed in Air-Handling Spaces (

Manufactured with UL94 V-0 rated engineering thermoplastic.

Warranty

2-year limited warranty.
For warranty information go to www.rheiacomfort.com/contact.



4" duct to 3" duct 90 degree elbow



3" duct to 3" duct 90 degree elbow

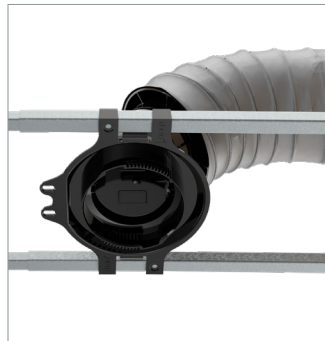

Ceiling boot with 45-Degree Elbow



Ceiling boot with two 45-Degree Elbows



Floor boot with 45-Degree Elbow



45-Degree Elbow Extension

DIMENSIONS

Part Dimensions:

Part #: 10-10-020
Length: 4.1" (102.8 mm)
Width: 3.1 (79.5mm)
Height: 3.8" (95.4 mm)

Part Weight: 0.13 lbs.